

CHANDLER 35 PTT-FT EXW FERTILIZER AND LIME SPREADER



- Heavy Walking Beam Tandem Axle
- 700/40 – 22.5 Floatation Tires
- Wider Spread Patterns
70' Fertilizer
50' Lime
- Mesh Type Chain or Optional Belt-Over Bar

- Dished Type Spinners Designed for Maximum Coverage on Spread Pattern
- Tandem Pump System with 50-Gallon Hydraulic Oil Tank
- Control Systems available from Raven Industries



The 30 PTT-FT-EXW is the latest in the EXW line. This spreader has the same dependability, accuracy and reliability that Chandler Spreaders have been known for over the past forty years. This spreader is truly in a class by itself with *NEW Walking Beam Tandem Axle*, floatation tires, and wider spread patterns. Designed for the grower/applicator that is not yet ready to step up to a big self-propelled floatation machine but already has 200-300 HP tractors on their farm and needs something bigger than your average pull type spreader.

This spreader has a capacity of 10-ton Fertilizer and 12-ton Lime with application rates from 50 # per acre to over 800 # per acre on fertilizer and from 500# to over 4 Tons per acre on lime with ground speeds up to 14 mph.

To learn more about our EXW line of spreaders contact Chandler Equipment or your nearest dealer.

Chandler Equipment Co.

Gainesville, Georgia 30503 – 770-536-8891
Toll Free 1-800-243-3319, 770-535-1265 Fax
www.chandlerequipment.net

Chandler 35 PTT – FT EXW

Specifications

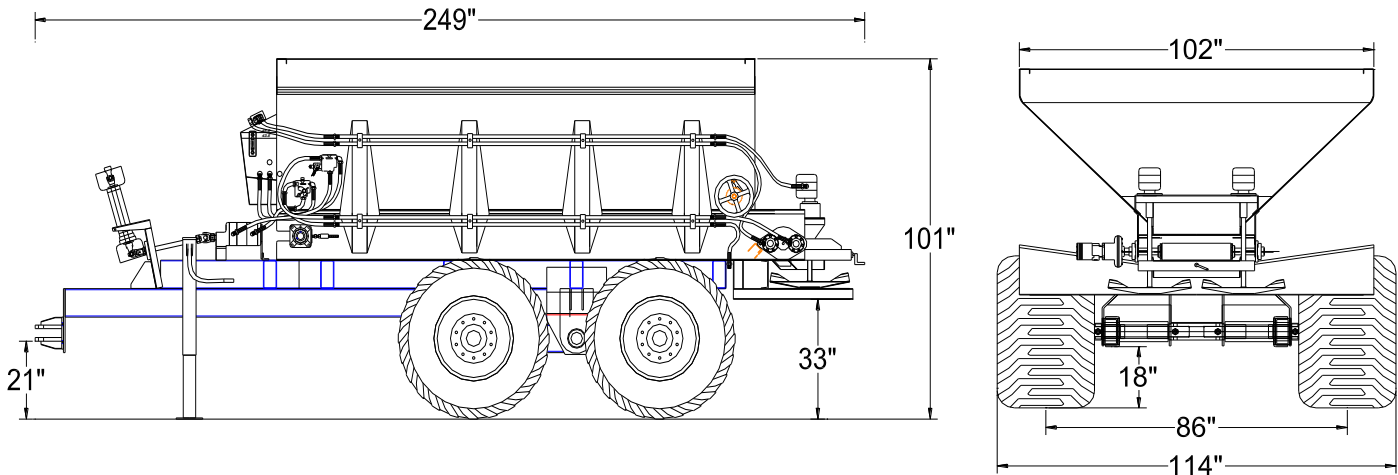

All Products and Specifications subject to change without notice. .

Hopper Construction:

Available in three types of material: Mild Steel, 409 Stainless Steel, and 304 Stainless Steel

Conveyor Specs:

Available in three types: 24" - 1" x 1" Mesh Type-304 Stainless Steel, Bar Type Chain and Belt Over – Bar type Chain

	Fertilizer @ 65 #)	Lime @ 90 #
Hopper Capacity (Struck Level)	280 Cu. Ft.	
Payload (struck level).....	18220 Lbs.	24,000 Lbs
Hopper Capacity (Heaped & Tarped)	310 Cu Ft.	
Payload (Heaped)	20,150 Lbs.	28,000 Lbs.



*Spread Patterns: Fertilizer up to 70'
Lime up to 50'*



Tandem Axle Walking Beam Suspension

Chandler Equipment Co.

Gainesville, Georgia 30503 – 770-536-8891
Toll Free 1-800-243-3319, 770-535-1265 Fax
www.chandlerequipment.net