

Chandler Auger Tenders

Superior! Economically Priced

(Side Discharge)



24-Ton Multi-hopper

Fertilizer Auger
Tender

Hydraulically
Operated

D.O.T. Spec. Trailer

Construction:

Mild Steel

409 Stainless Steel

or

304 Stainless Steel



24 Ton Side Discharge Tender
with a Single Folding Auger

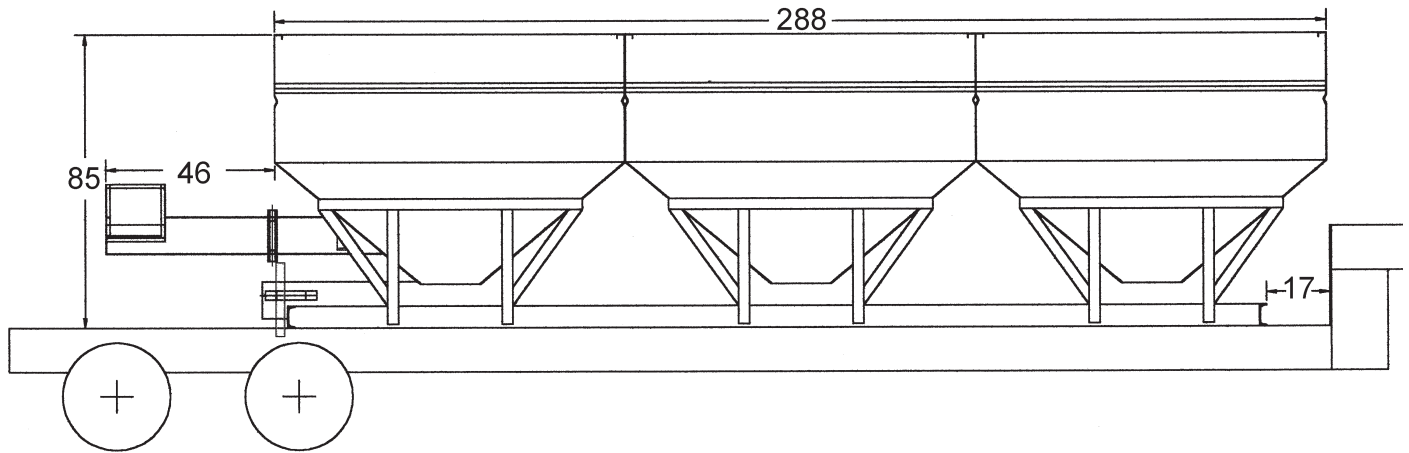

Based on truck frame height of 36 inches.

CAPACITIES

65# Material

- Hopper capacity (water level) 740 Cubic Ft. (20.95 Cubic Meters)
- Payload (water level) 48100 Lbs. (21817 Kilograms)
- Hopper capacity (heaped tarped) 830 Cubic Ft. (23 Cubic Meters)
- Payload (heaped, tarped) 53950 Lbs. (24471 Kilograms)

HOPPER DIMENSIONS

- Hopper length 24 Ft. (4.88 Meters)
- Hopper width 8 Ft. (2.44 Meters)
- Hopper height above trailer frame 7 Ft. (2.13 Meters)

AUGER SPECS

- Tube size 10 in. (254 MM)
- Discharge capacity 3500 Lbs./Minute (15.88 Kilograms/Minute)
- Discharge height (maximum) 12 Ft. 4 in. (4.04 Meters)
- Discharge height (minimum) 11 Ft. 7 in. (3.53 Meters)

STANDARD FEATURES

- Stainless gate slides
- Stainless gate sleeves and shafts
- Stainless gate fasteners
- Stainless transition box
- Stainless hopper boot
- Rear discharge pit dump on horizontal auger
- Stainless hinged shaft
- Rear mounted ladder
- Auger clean-out door
- Tarp support
- Six compartments

OPTIONAL FEATURES

- Stainless hopper and compartment bulkhead.
- Stainless gussets.
- Stainless auger tube.
- Stainless flighting mounted on stainless pipe.
- Additional ladder at front.
- Hydraulic drive.
- Shur Loc Roll Tarp.
- Catwalk on top of hoppers.

Chandler SDT – MH 24 Semi-Trailer Specifications

Trailer

Length: 40'

Width: 8'

Main Frame: 14 Inch @ 43 # w/ 6" Bridge from neck to suspension

King Pin Setting: 18"

King Pin Height: 49"

Suspension: Hutch 9700 – 25,000 #

Axles: Two (2) 71 ½" Track @ 25,000 Capacity Each

Hubs: Budd 10 Hole

Wheels: 22.5 Budd Steel Wheels

Tires: 255/70R 22.5 (11R22.5) Radial Tires

Brakes: Spring Brake on Air

Landing Gear: 2 Speed Crank Down

Bumper: DOT approved with Mud flaps

Lights: Sealed Beams

Trailer Weight: 8,500 #

Hopper

Length: 24'

Width: 96"

Number of Hoppers: 3

Compartments: 6

Capacity: 24 – Tons (based on 65# per cubic ft. material)

Empty Weight: 8,000 # (hopper only)

Auger and Tube Assembly

Auger Tube: 10" 304 Stainless Steel

Auger: 9 1/2" – 304 Stainless Steel Flighting and Pipe

Engine

Type: Duetz Diesel

Horse Power: 62

Engine Weight: 620 #

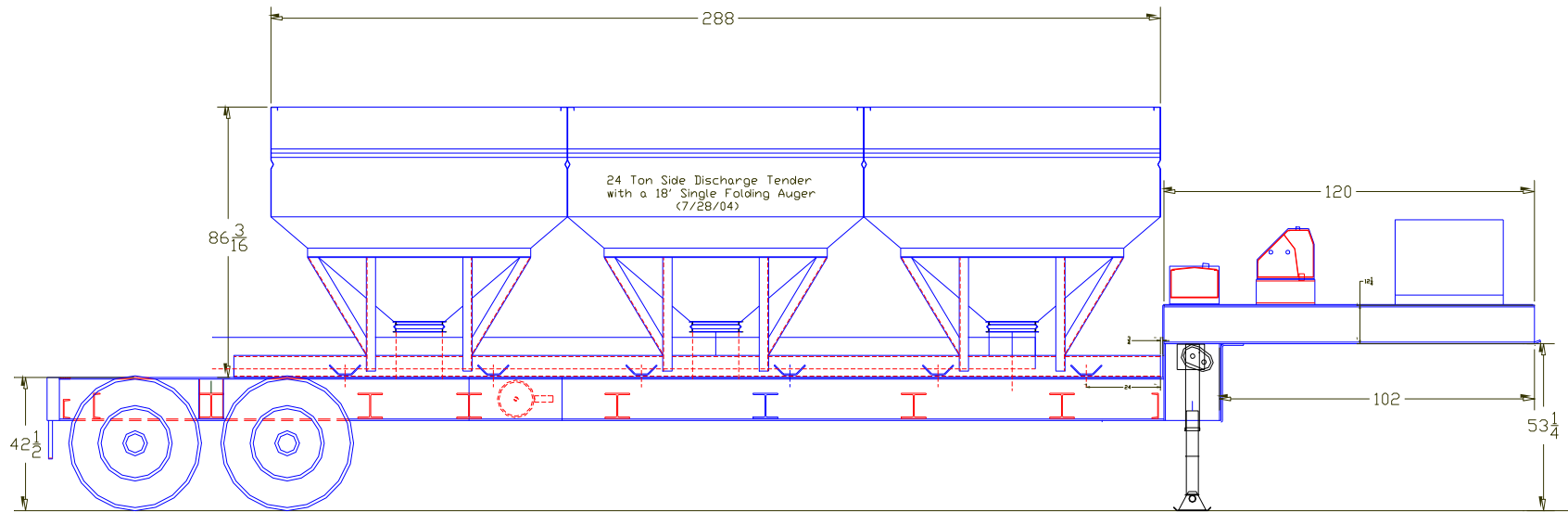

**Chandler SDT – MH 24 Ton
Semi-Trailer Tender Empty Weight 17,940 #**

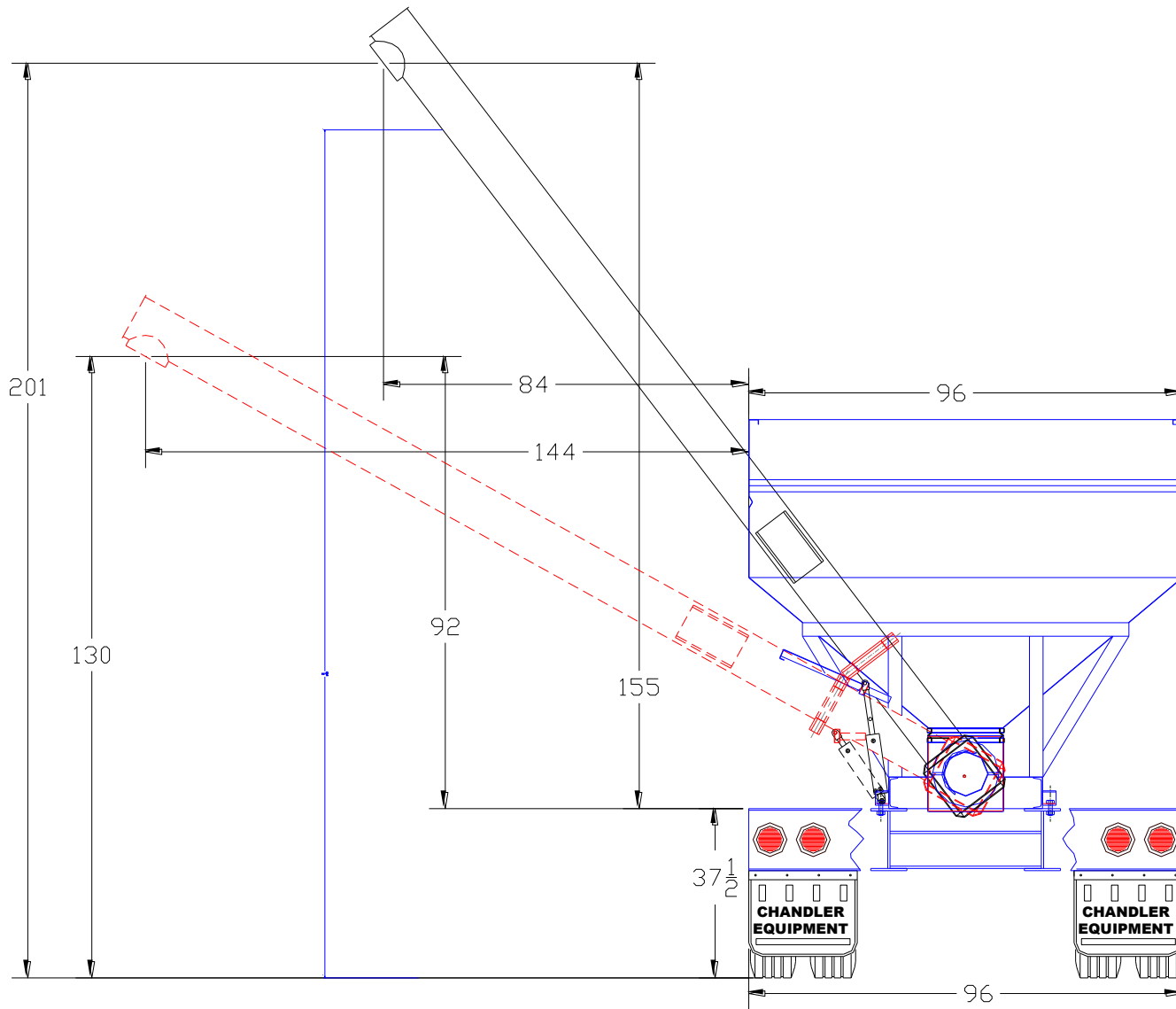

Chandler SDT – MH 24 Ton Discharge Height