



I-Feeder Technologies (UK) Ltd

Dosing System Design and Innovation

MXD INSTRUCTIONS



Installation and operating instructions

YOUR LEADER IN DOSING TECHNOLOGY

GENERAL DESCRIPTION

MXD pumps are heavy duty, precision, electric diaphragm positive displacement pumps.

This dosing pump consists of one main gearbox with dosing head. This unit forms the main drive of the dosing pump. What makes the MXD pump special is the capability to add as many extras dosing units to the drive unit. This allows volumes from 10 liters per hour up to any volume imaginable. Each of these dosing units can be independently regulated by means of a positive adjustment caliper.

Dosing units can be designed in such a manner that several different volumes or products can be dosed or the total volume can be increased. Increased dosing units allow higher permissible operating pressure, higher level of precision dosing & greater flexibility in the products being dosed into the injection line. When four (4) injection units are combined, it is possible to obtain straight line dosing, instead of the pulsed flow usually found with positive displacement dosing pumps. Dosing units can be added at a later stage as required or at the point of manufacture. Dosing pumps are also upgradeable in volume as required.

I-FEEDER MXD dosing pumps are manufactured with materials that can resist most chemicals products, even acids. They are designed for all sorts of processes where it is necessary to dose a product into a hydraulic network, such as: food, textile, chemical industry, water treatments, etc. (See materials in Technical Features). In case there is any doubt about compatibility of materials with the products to be used please contact I-FEEDER GLOBAL Technical Service.

Each injection unit can be controlled independantly with no need to stop operation when adjusting the pump volume.

The original packing is prepared so that carriage and storing of the product do not cause any damage to the product, as long as this is done far from heat sources and in dry, ventilated spaces.

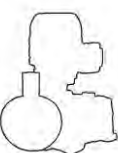

CONTENTS

		Pg
A	General	3
A1	Introduction	3
A2	Service documentation	3
1.	General Information	4
1.1	Applications	4
1.2	Warranty	4
2.	Safety	4
2.1	Identification of safety instructions	4
2.2	Qualification and training	4
2.3	Risks	4
2.4	Safety conscious	4
2.5	Safety instructions	4
2.6	Safety for maintenance, inspection and installation	4
2.7	Unauthorised modification and manufacture	4
3.	Type Key	5
B	Technical data	6
4.	Pump Performance	6
4.1	Accuracy	6
4.2	Performance	6
4.3	Suction heights	6
C	Dimensions	7
5.	Installation	8
5.1	General	8
5.2	Electrical Connection	8
6	Commissioning	8
6.1	Checks before start-up	8
6.2	Start-up	8
6.3	Switching on/ off	8
7	Installation tips	8
8	Tube/ Pipe lines	8
8.1	General	8
8.2	Connecting suction & Discharge lines	8
8.3	Suction	9
8.4	Injection	9
8.5	Dosing Flow	9
D	Installation drawing	10
9	Maintenance	11
9.1	General notes	11
9.2	Replacing the diaphragm	11
9.3	Periodical maintenance	11
10	Transport & Storage	11
10.1	Delivery	11
10.2	Intermediate storage	11
10.3	Unpacking	11
10.4	Return	11
11	Fault finding chart	12
12	Dosing curves	13
E	Parts list	14
F	Warranty	15



Warning

Prior to installation, read these installation and operating instructions. Installation and operation must comply with local regulations and accepted codes of good practice.

A. General

A1 Introduction

These installation and operating instructions contain all the information required for starting up and handling the MXD-D dosing pump.

If you require further information or if any problems arise, which are not described in detail in this manual, please contact the nearest I-Feeder company.

A2 Service documentation

If you have any questions, please contact the nearest I-Feeder company or service workshop.



SAFETY RULES

To avoid personal or environmental damages and to guarantee a proper operation of the equipment, the staff in charge of the installation, set up and maintenance of the equipment must follow the instructions of this manual, specially those recommendations and warnings explicitly detailed. In addition, specific instructions for the chemical products to be dosed should be followed.

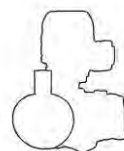

1. General information

1.1 Applications

The MXD-D pump is suitable for liquid, non-abrasive and non-inflammable media strictly in accordance with the instructions in this manual.



Warning

Other applications or the operation of pumps in ambient and operating conditions, which are not approved, are considered improper and are not permitted. Irriquip CC accepts no liability for any damage resulting from incorrect use.

1.2 Warranty

Warranty in accordance with our general terms of sale and delivery is only valid

- if the pump is used in accordance with the information within this manual.
- if the pump is not dismantled or incorrectly handled.
- if repairs are carried out by authorised and qualified personnel.
- if original spare parts are used for repairs.

2. Safety

This manual contains general instructions that must be observed during installation, operation and maintenance of the pump. This manual must therefore be read by the installation engineer and the relevant qualified personnel/operators prior to installation and start-up, and must be available at the installation location of the pump at all times.

It is not only the general safety instructions given in this "Safety" section that must be observed, but also all the specific safety instructions given in other sections.

2.1 Identification of safety instructions in this manual

If the safety instructions or other advice in this manual are not observed, it may result in personal injury or malfunction and damage to the pump. The safety instructions and other advice are identified by the following symbols:



Warning

If these safety instructions are not observed, it may result in personal injury!

Caution

If these safety instructions are not observed, it may result in malfunction or damage to the equipment!

Note

Notes or instructions that make the job easier and ensure safe operation.

Information provided directly on the pump, e.g. labelling of fluid connections, must be observed and must be maintained in a readable condition at all times.

2.2 Qualification and training of personnel

The personnel responsible for the operation, maintenance, inspection and installation must be appropriately qualified for these tasks. Areas of responsibility, levels of authority and the supervision of the personnel must be precisely defined by the operator.

If the personnel do not have the necessary knowledge, the necessary training and instruction must be given. If necessary, training can be performed by the manufacturer/supplier at the request of the operator of the pump. It is the responsibility of the operator to make sure that the contents of this manual are understood by the personnel.

2.3 Risks when safety instructions are not observed

Non-observance of the safety instructions may have dangerous consequences for the personnel, the environment and the pump. If the safety instructions are not observed, all rights to claims for damages may be lost.

Non-observance of the safety instructions may lead to the following hazards:

- failure of important functions of the pump/system
- failure of specified methods for maintenance
- harm to humans from exposure to electrical, mechanical and chemical influences
- damage to the environment from leakage of harmful substances.

2.4 Safety-conscious working

The safety instructions in this manual, applicable national health and safety regulations and any operator internal working, operating and safety regulations must be observed.

2.5 Safety instructions for the operator/user

Hazardous hot or cold parts on the pump must be protected to prevent accidental contact.

Leakages of dangerous substances (e.g. hot, toxic) must be disposed of in a way that is not harmful to the personnel or the environment. Legal regulations must be observed.

Damage caused by electrical energy must be prevented.

2.6 Safety instructions for maintenance, inspection and installation work

The operator must ensure that all maintenance, inspection and installation work is carried out by authorised and qualified personnel, who have been adequately trained by reading this manual.

All work on the pump should only be carried out when the pump is stopped. The procedure described in this manual for stopping the pump must be observed.

Pumps or pump units which are used for media that are harmful to health must be decontaminated.

All safety and protective equipment must be immediately restarted or put into operation once work is complete.

Observe the points described in the initial start-up section prior to subsequent start-up.

Warning



Electrical connections must only be carried out by qualified personnel!

The pump housing must only be opened by personnel authorised by I-FEEDER!

2.7 Unauthorised modification and manufacture of spare parts

Modification or changes to the pump are only permitted following agreement with the manufacturer. Original spare parts and accessories authorized by the manufacturer are safe to use. Using other parts can result in liability for any resulting consequences:

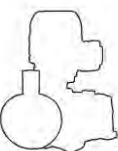

3 Type key

	MXD	XX	X	X	X	X	X	X	X	X	X	X	X	X	X
Type range															
Model number															
Maximum counter-pressure [bar]															
Control variant															
B	Standard - manual control														
AR*	Analog/pulse control 4-20 mA control														
VSD	Variable speed control														
Dosing head variant															
PP	Polypropylene														
PV	PVDF (polyvinylidene fluoride)														
PVC	Polyvinyl chloride														
SS	Stainless steel, SUS 316														
PV-R	PVDF + integrated relief valve														
PVC-R	PVC + integrated relief valve														
Gasket material															
E	EPDM														
T	PTFE														
Valve ball material															
G	Glass														
C	Ceramic														
SS	Stainless steel														
Control panel position															
X	no control panel														
Motor variant															
E0	PTC motor for frequency control														
E1	Motor type 400 V,														
E2	Motor type 220 V,														
Mains plug															
X	no plug														
Connection, suction/discharge															
4	Tubed														
6	Cemented														
8	Threaded, male														
Valve type															
1	Standard valve														
3	0.05 bar suction opening pressure 0.8 bar discharge opening pressure														
4	Spring-loaded, discharge side only 0.8 bar opening pressure														
5	Valve for abrasive media														
Supply voltage															
G	230 V, 50/60 Hz														
E	380 V, 50/60 Hz														

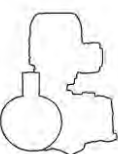

TECHNICAL :

Model-MXD	82S	23S	34S	53S	63S	14S	20S	16S
Max. discharge volume (l/HR)	50	100	200	300	400	600	900	1200
Max. discharge pressure (Bar)	10	10	10	10	7	10	8	6
Stroke length (mm)	12.5							
Strokes per minute	36	72	36	58	72	116	58	232
Connection type/ aperture	K15A				K25A			
Transferrable viscosity (mPa*s)	Ceramic check ball: 100 mPa*s Stainless steel check ball: 3000 mPa*s							
Transferrable temperature (°C)	Pump head material: Stainless steel * PVDF: 0-60°C PVC: 0-40°C							
Electric motor	Voltage	220 V (single-phase) or 380V (three-phase) available						
	Poles	4	4	4	4	2	4	4
	kW	0.25		0.37		0,55		0,75
Pump paint color	Hammertone Blue							
Weight (kg)	25		27	27		27	29	29

Liquid End Materials				
Material/ Type	VEC	VES	SES	FTC
Pump Head	PVC	PP	SUS304	PVDF
Diaphragm	EPDM	EPDM	EPDM	PTFE
Check Ball	Ceramic	SUS316	SUS316	Ceramic
Joint	PVC	PP	SUS304	PVDF
O-ring	Fluoro-rubber		PTFE	PTFE

PROTECTION:IP-55

4 Pump performance

4.1 Accuracy

- Dosing flow fluctuation: $\pm 1.5\%$ within the control range 1:10
- Linearity deviation: $\pm 4\%$ of the full-scale value. Adjustment from max. to min. stroke length, within the control range 1:5.

Applies to:

- water as dosing medium
- fully deaerated dosing head
- measurement according to IRRQUIP factory standard no. 0027/0813
- standard pump version.

4.2 Performance

Applies to:

- maximum counter-pressure
- water as dosing medium
- flooded suction 0.5 mWC
- fully deaerated dosing head
- three-phase 400 V motor.

4.3 Suction heights (See chart below)

4.3.1 Media with a viscosity similar to water

Applies to:

- counter-pressure of 1.5 to 10 bar
- non-degassing and non-abrasive media
- temperature of 20 °C
- stroke length 100 %.

Pump type	50 Hz		60 Hz		Maximum length of suction line [m]
	Suction height* [mWC]	Intake height** [mWC]	Suction height* [mWC]	Intake height** [mWC]	
MXD 82S	4	3	4	3	4
MXD 23S	4	3	4	3	4
MXD 63S	3	2	3	2	3
MXD 53S	2	1	2	1	2
MXD 14S	2	1	2	1	2
MXD 20S	1	1	1	1	2
MXD 16S	1	1	1	1	2

* Suction line and dosing head filled (continuous operation)

** Suction line and dosing head not filled.

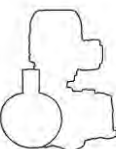

DIMENSIONS:

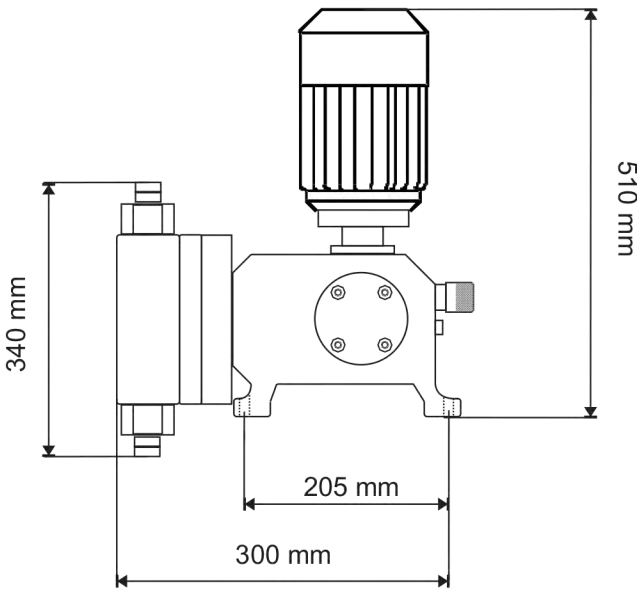
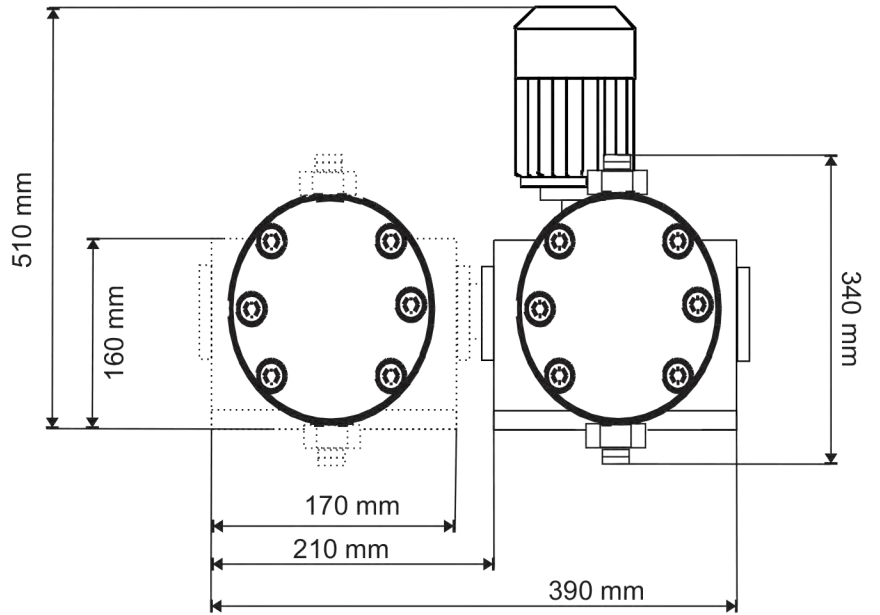

Side Dimensions

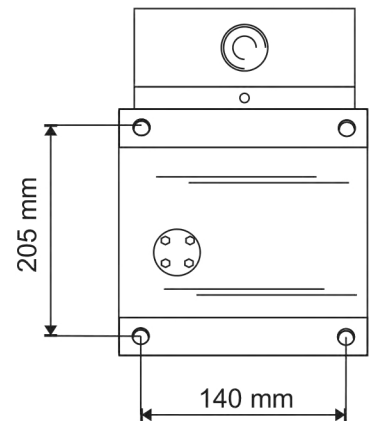

Foot Dimensions

Recommendations for the correct installation

SUCTION PIPE

⚠ Long suction pipe: L>2m (6.5ft)

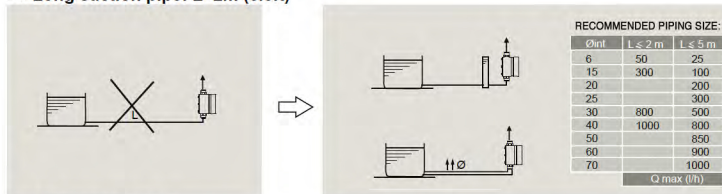

⚠ Air in suction pipe

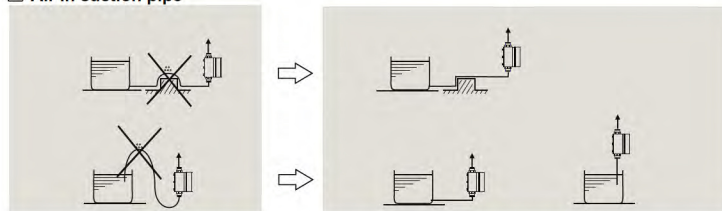

DISCHARGE PIPE

⚠ Long discharge pipe: L>5m (16 ft)

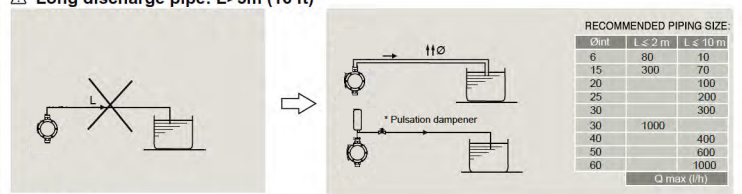

⚠ Siphon

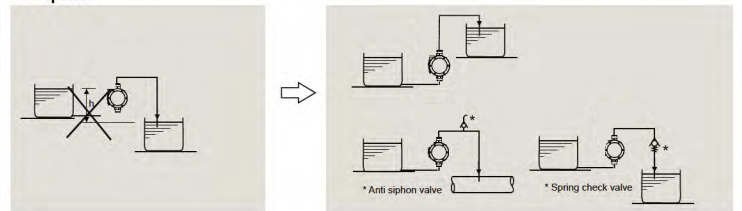

5 INSTALLATION

5.1 GENERAL

To install this pump it is advisable to choose places protected from water, away from heat sources and air renewal.

Place the pump vertically over a rigid surface to achieve proper distribution of lubrication. Anticipate spaces needed for maintenance and installation.



The electric protection of the motor must be installed and adjusted following its nominal intensity (overloaded switch disjunctor). (See wiring).

A disconnection overload must be installed in case of emergency.

The equipment must be protected to avoid untimely sudden starts.

THREE-PHASE CONNECTION (50/60 Hz)

To work at 230 V we will plug the motor in delta

To work at 400 V it will be a star connection.

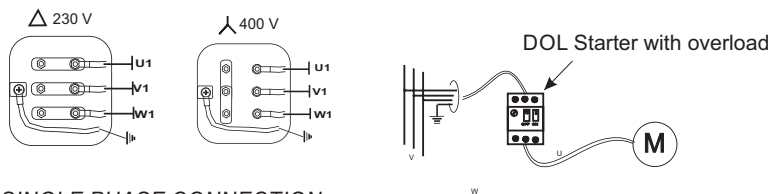

SINGLE PHASE CONNECTION

To work at 230 V single-phase at 50 Hz we will connect directly the motor wire to the adequate protection. To work at 60 Hz we will connect the connection box plates as shown in the drawing.

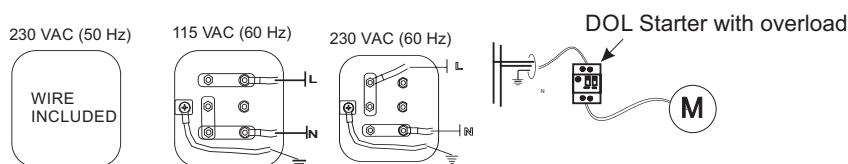

6. Commissioning

6.1 Checks before start-up

- Check that the rated voltage stated on the pump nameplate corresponds to the local conditions!
- Check that all connections are secure and tighten, if necessary.
- Check that the dosing head screws are tightened with the specified torque and tighten, if necessary.
- Check that all electrical connections are correct.

6.2 Start-up

After initial start-up and after each time the diaphragm is changed, tighten the dosing head screws.

Caution After approximately 6-10 operating hours or two days, cross-tighten the dosing head screws using a torque wrench.

Maximum torque: 6 Nm.

1. Open the deaeration valve, if installed, in the discharge line, or relieve the pressure on the discharge side so that the medium can run out without a counter-pressure.
2. Switch on the power supply.
3. Set the stroke-length adjustment knob to 100 %.
4. Leave the pump running until the dosed medium is free of air bubbles.
5. Close the deaeration valve, if installed.
 - The pump is now ready for operation.

Functional principle

- Reciprocating displacement pump with electric motor and mechanical diaphragm control.
- The rotation of the motor is transformed into the reciprocating movement of the dosing diaphragm by the eccentric and the tappet.
- The dosing flow can be set by adjusting the stroke length of the tappet.

6.3 Switching on/off

Caution Before switching on the pump, check that it is installed correctly.

- To start the pump, switch on the power supply.
- To stop the pump, switch off the power supply.

7 Installation tips

- For easy de-aeration of the dosing head, install a ball valve with bypass line (back to the dosing tank) immediately after the discharge valve.
- In the case of long discharge lines, install a non-return valve in the discharge line.
- When installing the suction line, observe the following:
 - Keep the suction line as short as possible. Prevent it from becoming tangled.
 - If necessary, use swept bends instead of elbows.
 - Always route the suction line up towards the suction valve.
 - Avoid loops which may cause air bubbles.

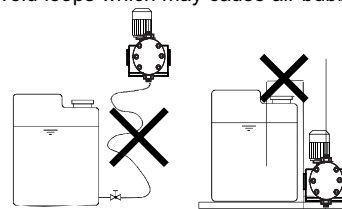

- For media with a tendency to sedimentation, install the suction line with filter so that the suction valve remains a few millimetres above the possible level of sedimentation.

8. Tube / pipe lines

8.1 General

Warning

Only use the prescribed line types!

All lines must be free from strain!

Avoid loops and buckles in the tubes!

Keep the suction line as short as possible to avoid cavitation!

If necessary, use swept bends instead of elbows.

Observe the chemical manufacturer's safety instructions when handling chemicals!

Make sure that the pump is suitable for the actual dosing medium!

The flow must run in the opposite direction to gravity!



Caution The resistance of the parts that come into contact with the media depends on the media, media temperature and operating pressure. Ensure that parts in contact with the media are chemically resistant to the dosing medium under operating conditions!

8.2 Connecting the suction and discharge lines



Warning

All lines must be free from strain!

Only use the prescribed line types!

- Connect the suction line to the suction valve.
 - Install the suction line in the tank so that the foot valve remains 25 to 30 mm above the bottom of the tank or the possible level of sedimentation.
- Connect the discharge line to the discharge valve.

8.3 SUCTION

It is essential to fit in the suction of the dosing liquid the filter of 500 mesh.

Couple the suction pipe to the lower connector of the cylinder, putting the mesh filter inbetween. The sediment at the bottom of the tank must never be suctioned, to avoid suction of undiluted parts.

The piping must be stiff enough so that it does not lose its shape when there is suction.

To help suction the piping must be as short as possible, the pipe diameter must be at least 40 mm. For pipes of over 3 m, diameter must be increased.

8.4 INJECTION

Fix the check valve supplied with the pump at the input of the water network, as shown in the drawing, and couple the injection hose to the upper connector of the cylinder.

The pipe diameter will have to be the same as the valve diameter. For pipes over 15m length the diameter shall be increased. Do never insert a shutoff valve.

8.5 DOSING FLOW

Through the micrometric regulator adjust the dosing flow from 0 to 100 % depending on the wished value. A regulation inferior than 10% is not advisable.

In order to check the dosing flow:

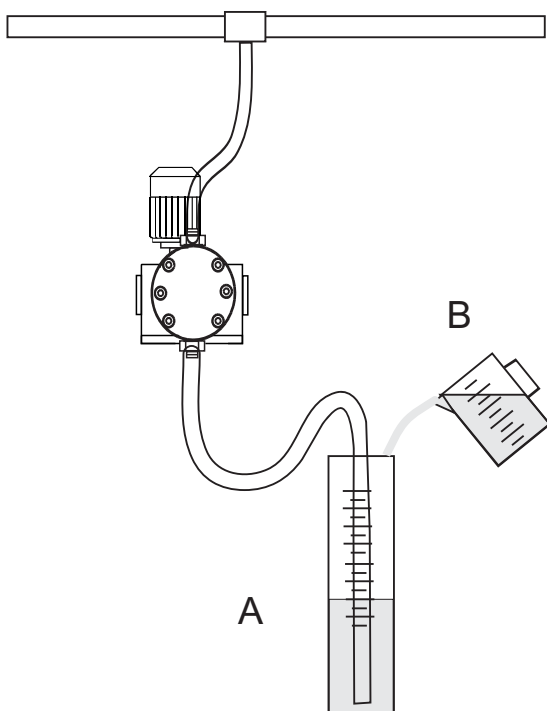

- 1.- Prime the pump immersing the suction pipe in graduated receptacle (A)
- 2.- Mark in the receptacle the liquid level.
- 3.- Start up the pump and pour a known volume (V) of measured liquid in a second receptacle (B).
- 4.- Measure the time (t) that goes between the start up of the pump and the precise instant in which the liquid reaches the level of the mark of receptacle A.
- 5.- The dosed flow corresponds to:

$$Q(l/h) = V \text{ (liters)} / t \text{ (seconds)} \times 3600$$

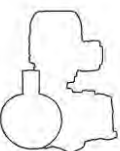

INSTALLATION LIST

ITEM	QTY	DESCRIPTION
1	1	I-FEEDER MXD METERING/DOSING PUMP
2	1	I-FEEDER MG MIXER/AGITATOR
3	2	I-FEEDER HYDROFOIL IMPELLOR
4	1	MIXING VESSEL/TANK FOR CHEMICALS
5	2	MANUAL MOTOR STARTER WITH ISOLATER AND PLUG POINT
6	2	PVC ELBOW FEMALE THREAD
7	1	INJECTION QUILL 1 1/4" : 20 MM MALE THREAD
8	1	FEMALE THREAD : MALE PIPE FITTING PVC
9	8	STAINLESS STEEL HOSE CLAMP
10	1	OUTLET PIPING PUMP TO QUILL
11	1	TANK FITTINGS MALE
12	1	TANK UNION/RUBBER
13	3	MALE THREAD: MALE THREAD PVC FITTING
14	1	T FITTING: FEMALE THREAD
15	3	ISOLATION TAP T-HANDLE: FEMALE THREAD
16	6	MALE THREAD: MALE PIPE PVC FITTING
17	1	SUPPLY PIPING *
18	1	SUPPLY PIPING
19	1	CHEMICAL FILTER SPECIFIED AS PER PUMP SIZE
20	1	SUPPLY PIPING
21	1	INJECTION POINT MAINLINE
22	1	IP67 PLUGPOINT
23	1	PRESSURE GAUGE

NOTES: * This inlet port can be used to fill up the vessel with water from the mainline, or as a suction point for calibration of the dosing unit.

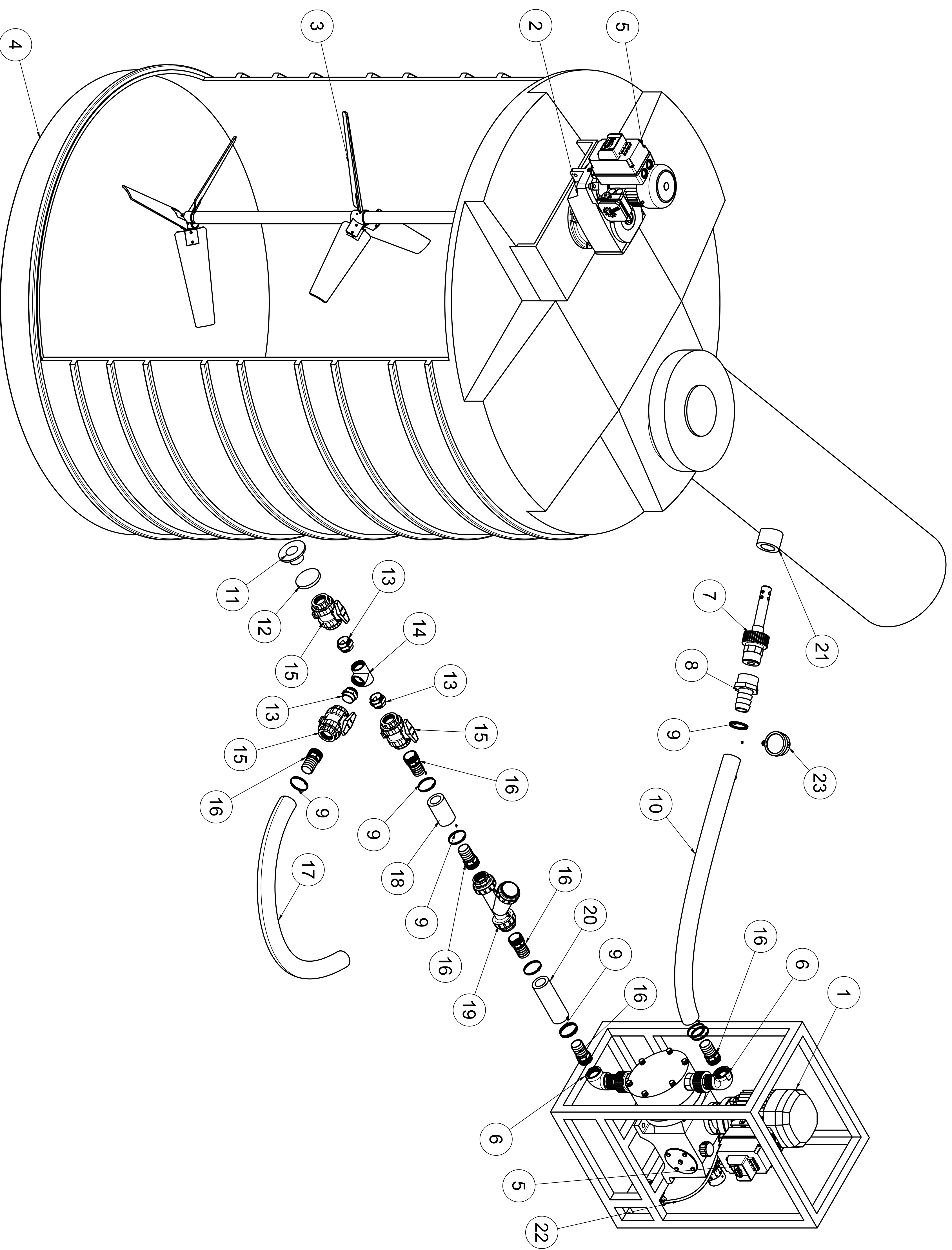

9. Maintenance

9.1 General notes

Warning

When dosing dangerous media, observe the corresponding safety precautions!

Risk of chemical burns!

Wear protective clothing (gloves and goggles when working on the dosing head, connections or lines!

Do not allow any chemicals to leak from the pump. Collect and dispose of all chemicals correctly!

Warning

The pump housing must only be opened by personnel authorised by Irriquip!

Repairs must only be carried out by authorised and qualified personnel!

Switch off the pump and disconnect it from the power supply before carrying out maintenance work and repairs!



Replacing the diaphragm

1. Loosen the six dosing head screws.
2. Remove the dosing head.
3. Turn the fan blades until the diaphragm reaches the front dead centre (the diaphragm detaches itself from the diaphragm flange).
4. Unscrew the diaphragm by manually turning it counter-clockwise.
5. Check the parts and replace by new ones, if necessary.
6. Screw in the new diaphragm completely. Then turn it back until the holes in the diaphragm and the flange coincide.
7. Turn the fan blades until the diaphragm reaches the bottom dead centre (the diaphragm is pulled onto the diaphragm flange).
8. Refit the dosing head carefully and cross-tighten the screws. Maximum torque: 6 Nm.
9. Deaerate and start the dosing pump.

Before any maintenance operation we will check:

That the pump is stopped and disconnected from the electric supply.

There is no pressure neither inside the head nor in the impulsion pipe. It is advisable to empty the head before opening it.

The staff in charge of the maintenance will use the adequate protection means in order to manipulate the dosed liquid.



PERIODICAL MAINTENANCE:

Change oil after the first 500 hours. Next changes will be every 2000 hours (minimum once a year).

Check the diaphragm every 3 months or 1000 hours.

Check the suction filter before and after operation..

Check the valves every 3 months or 1000 hours.

It is advisable to periodically clean the dosing unit, letting clean water flow through it (we can make it coincide with the emptying of the tank), to eliminate precipitated rests that can remain in the inner part of the cylinder or in suction / impulsion pipes.

If we are using highly corrosive liquids it is advisable to double the frequency of checkings.



OIL: Take off re-filling lid and fill the pump with the provided oil: 320 GRADED OIL. If the pump has several boxes oil must be filled into all boxes.

Approximate oil capacity: 1 liter per gearbox. When carrying, keep upright.



CHECKING THE HYDRAULIC CIRCUIT: Check that all valves are opened and that escapes from priming valves derive the liquid to a proper receptacle.



ROTARY DIRECTION: Start up the pump to check that the rotary direction coincides with the one shown by the arrow. To change rotary direction invert two phases in the motor terminals box.



CHECKING OF PUMP: Check visually/auditorilly the proper working of the pump.

10. Transport and storage

Do not throw or drop the pump.

Store the pump in a dry and cool place.

Store the pump in upright position so that the

Caution gear oil cannot leak out.

Do not use the protective packaging as transport packaging.

Observe the permissible storage temperature!

10.1 Delivery

The MXD type dosing pumps are supplied in different packaging, depending on pump type and the overall delivery. For transport and intermediate storage, use the correct packaging to protect the pump against damage.

10.2 Intermediate storage

- Permissible storage temperature: -20°C to $+50^{\circ}\text{C}$.
- Permissible air humidity: max. relative humidity: 92 % (non-condensing).

10.3 Unpacking

Retain the packaging for future storage or return, or dispose of the packaging in accordance with local regulations.

10.4 Return

Return the pump in its original packaging or equivalent.

The pump must be thoroughly cleaned before it is returned or stored. It is essential that there are no traces of toxic or hazardous media remaining on the pump.

Caution

I-Feeder Technologies accepts no liability for damage caused by incorrect transportation or missing or unsuitable packaging of the pump!

Before returning the pump to I-Feeder Technologies for service, the **safety declaration** at the end of these instructions must be filled in by authorised personnel and attached to the pump in a visible position.

Caution

If a pump has been used for a medium which is injurious to health or toxic, the pump will be classified as contaminated.

If I-Feeder Technologies or agent is requested to service the pump, it must be ensured that the pump is free from substances that can be injurious to health or toxic. If the pump has been used for such substances, the pump must be cleaned before it is returned.

If proper cleaning is not possible, all relevant information about the chemical must be provided.

If the above is not fulfilled, I-Feeder Technologies can refuse to accept the pump for service. Costs of returning the pump are paid by the customer.

The safety declaration can be found at the end of these ins:

Caution The replacement of the supply cable must be carried out by an authorised Irriquip service workshop.

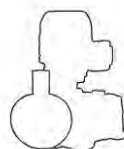

11. Fault finding chart

Fault	Cause	Remedy	
1. Dosing pump does not run.	a) Not connected to the power supply.	Connect the power supply cable.	
	b) Incorrect supply voltage.	Replace the dosing pump.	
	c) Electrical failure.	Return the pump for repair.	
	d) The empty indication has responded.	Remove the cause.	
	e) The diaphragm leakage detection has responded.	Replace the diaphragm.	
2. Dosing pump does not suck in.	a) Leaking suction line.	Replace or seal the suction line.	
	b) Cross-section of the suction line too small or suction line too long.	Check with I-Feeder specification.	
	c) Clogged suction line.	Rinse or replace the suction line.	
	d) Foot valve covered by sediment.	Suspend the suction line from a higher position.	
	e) Buckled suction line.	Install the suction line correctly. Check for damage.	
	f) Crystalline deposits in the valves.	Clean the valves.	
	g) Diaphragm broken or diaphragm tappet torn out.	Replace the diaphragm.	
	3. Dosing pump does not dose.	a) Air in the suction line and dosing head.	Wait, until the pump has deaerated.
		b) Stroke-length adjustment knob set to zero.	Turn the adjustment knob in the "+" direction.
c) Viscosity or density of medium too high.		Check the installation.	
d) Crystalline deposits in the valves.		Clean the valves.	
e) Valves not correctly assembled.		Assemble the inner valve parts in the right order and check and possibly correct the flow direction.	
4. Dosing flow of the pump is inaccurate.	f) Injection point blocked.	Check and possibly correct the flow direction (injection unit), or remove the obstruction.	
	g) Incorrect installation of lines and peripheral equipment.	Check the lines for free passage and correct installation.	
	a) Dosing head not fully deaerated.	Repeat the deaeration.	
	b) Degassing medium.	Check the installation.	
	c) Parts of the valves covered in dirt or incrusted.	Clean the valves.	
	d) Zero point misadjusted.	Adjust the zero point to the actual counter-pressure.	
	e) Counter-pressure fluctuations.	Install a pressure-loading valve and a pulsation damper.	
	f) Suction height fluctuations.	Keep the suction level constant.	
	g) Siphon effect (inlet pressure higher than counter-pressure).	Install a pressure-loading valve.	
	h) Leaking or porous suction line or discharge line.	Replace the suction line or discharge line.	
	i) Parts in contact with the medium are not resistant to it.	Replace with resistant materials.	
j) Dosing diaphragm worn (incipient tears).	Replace the diaphragm. Also observe the maintenance instructions.		
k) Supply voltage fluctuations.	Decrease the counter-pressure of the pump.		
l) Variation of the dosing medium (density, viscosity).	Check the concentration. Use an agitator, if necessary.		

Caution For further error signals for the control unit, refer to the relevant section.

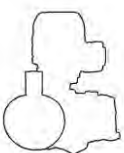

12. Dosing curves

The dosing curves on the following pages are trend curves.

They apply to:

- performance of simple pump (the flow rate is doubled for the double pump)
- water as dosing medium
- suction line with foot valve, 0.5 m flooded suction
- zero point of pump Q_0 for specified pressure, see table below
- standard pump version.

Abbreviation	Description
Q	Dosing flow
Q_0	Zero point of the pump The pumps are calibrated so that Q is 0 at 2 bar.
h	Stroke length

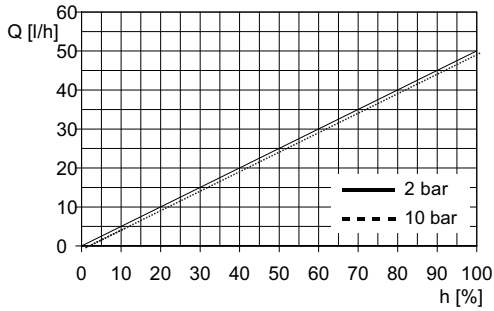

MXD-82S (50 Hz)

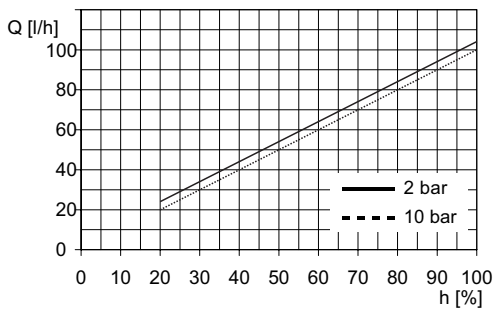

MXD-23S (50 Hz)

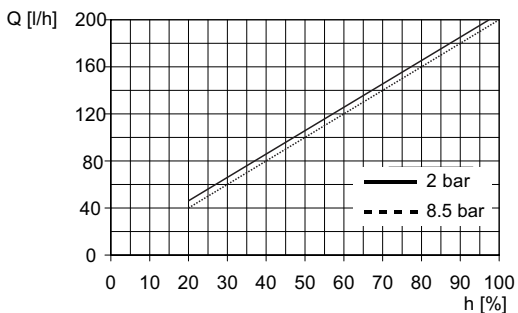

MXD-63S (50 Hz)

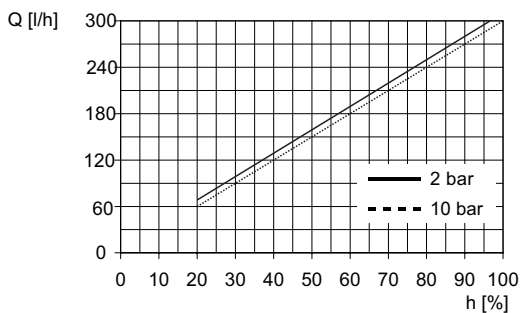

MXD-53S (50 Hz)

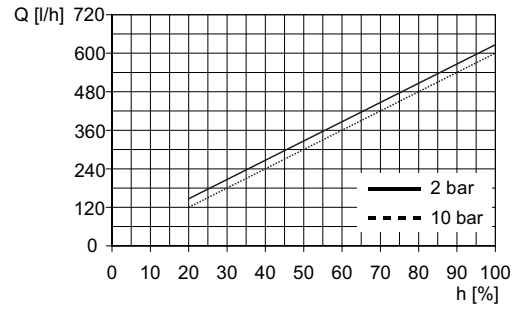

MXD-14S (50 Hz)

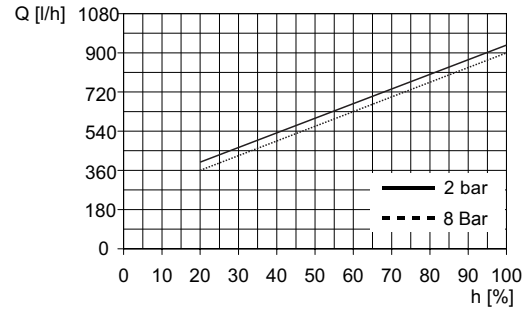

MXD-20S (50 Hz)

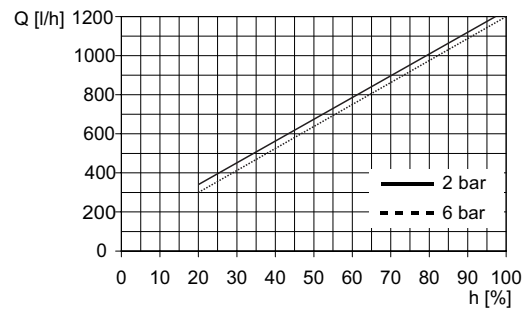

MXD-16S (50 Hz)

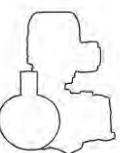

PARTS LIST			
ITEM	QTY	PART NUMBER	DESCRIPTION
1	3	K-34	BOLT M6 X 8 STAINLESS STEEL
2	3	K-37	COPPER WASHER M6
3	16	K-33	BOLT M6 X 20 MM STAINLESS STEEL
4	2	K-14	BEARING CAP MXD GEARBOX
5	2	K-44	BEARING MAIN SHAFT 6005 BEARING MAIN SHAFT
6	1	K-29	MAIN SHAFT SPACER
7	1	K-22A	WORM GEAR
8	1	K-26	MAIN SHAFT
9	1	K-27	ECCENTRIC BEARING BUSH
10	1	K-31	ECCENTRIC BEARING
11	1	K-28	ECCENTRIC CAM RETAINING RING
12	1	K-30	ECCENTRIC CAM CIRCLIP
13	1	K-41	BOTTOM CAP
14	1	K-19	OIL DRAIN PLUG
15	1	K-19A	OIL DRAIN COPPER WASHER M12
16	1	K-21	LEVEL INDICATOR
17	1	K-47	ADJUSTMENT COARSE
18	4	K-36	CAPSCREW M4 X 45 STAINLESS STEEL
19	1	K-48	ADJUSTMENT SHAFT
20	1	K-49	ADJUSTMENT CONTROL

PARTS LIST			
ITEM	QTY	PART NUMBER	DESCRIPTION
21	4	K-45	GRUBSCREW M6 X 8 STAINLESS STEEL
22	1	K-52	SETSCREW M6:45
23	1	K-20	OIL BREATHER CAP
24	1	K-22	WORM SHAFT
25	2	K-42	BEARING WORM SHAFT 6203 BEARING WORM SHAFT
26	1	K-12	RETAINER
27	4	K-53	BOLT M6:35
28	1	K-40	MOTOR FLANGE
29	1	MF-AC380	AC ELECTRIC MOTOR
30	2	K-38	DRIVE COUPLING
31	1	K-37	LO70 COUPLING RUBBER
32	2	K-01	1ST JOINT 1 1/4"
33	1	K-10A	BACKING RING
34	1	K-23	MAIN FLANGE
35	1	K-10	LARGE PUMP HEAD 190
36	1	MX-GB	MXD GEARBOX
37	2	K-02	VALVE
38	2	K-07	UNION NUT

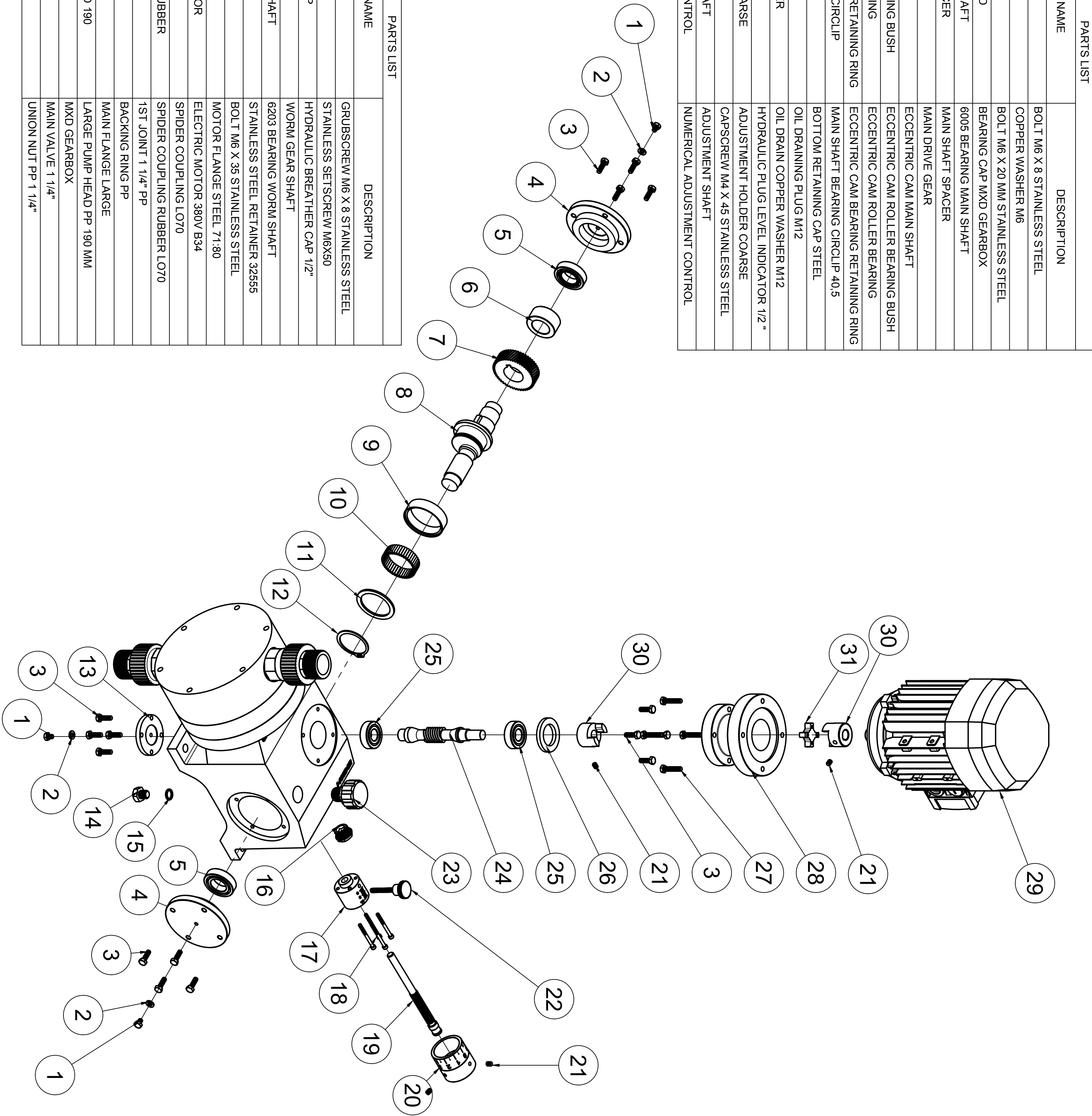

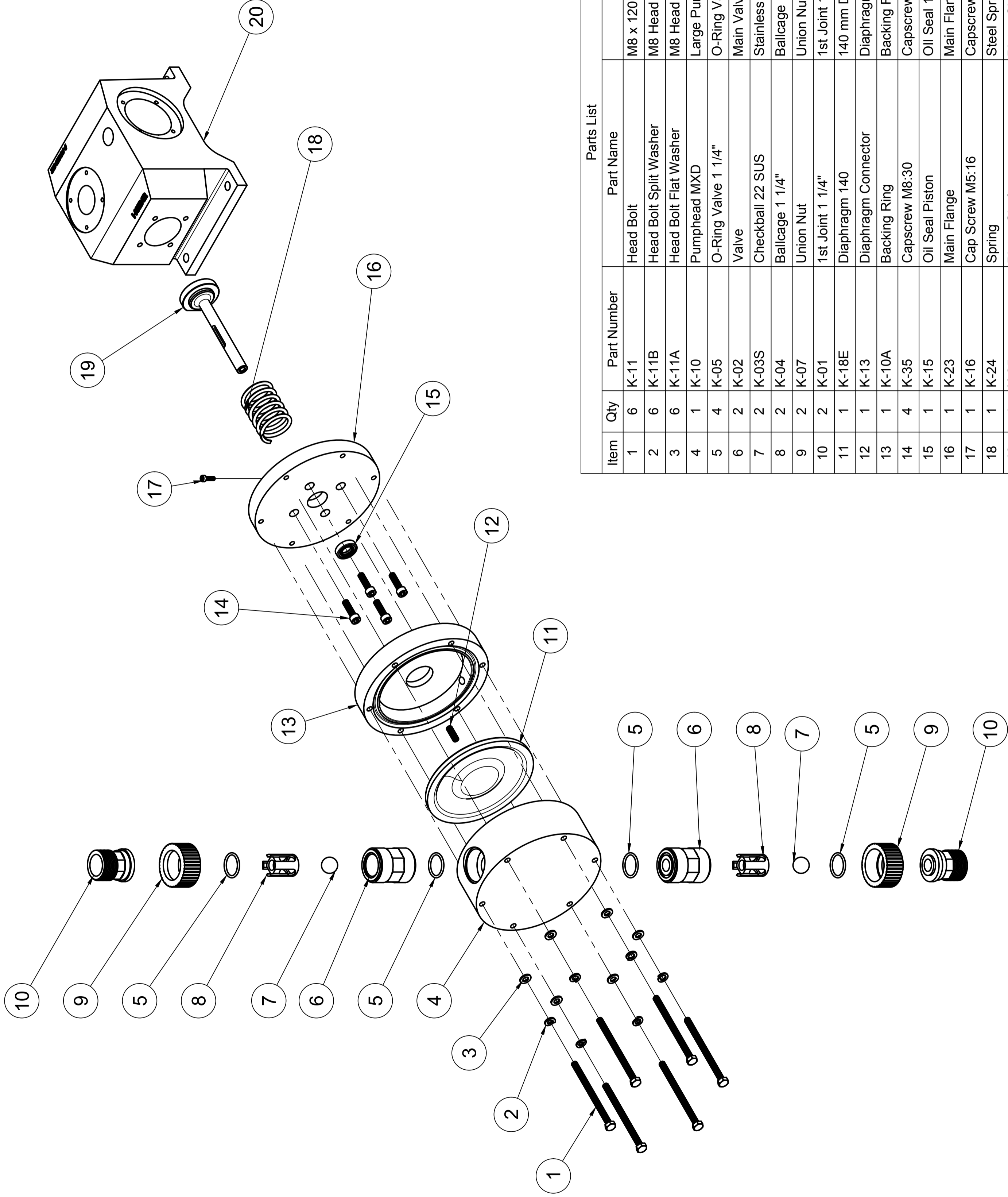

Parts List

Item	Qty	Part Number	Part Name	Description
1	6	K-11	Head Bolt	M8 x 120 Head Bolt Stainless Steel
2	6	K-11B	Head Bolt Split Washer	M8 Head Bolt Split Washer SUS
3	6	K-11A	Head Bolt Flat Washer	M8 Head Bolt Flat Washer SUS
4	1	K-10	Pumphead MXD	Large Pump Head PP
5	4	K-05	O-Ring Valve 1 1/4"	O-Ring Valve 1 1/4" EPDM
6	2	K-02	Valve	Main Valve 1 1/4"
7	2	K-03S	Checkball 22 SUS	Stainless Steel Check Ball 7/8"
8	2	K-04	Ballcage 1 1/4"	Ballcage 1 1/4" PP
9	2	K-07	Union Nut	Union Nut PP 1 1/4"
10	2	K-01	1st Joint 1 1/4"	1st Joint 1 1/4" PP
11	1	K-18E	Diaphragm 140	140 mm Diaphragm
12	1	K-13	Diaphragm Connector	Diaphragm Connector SUS
13	1	K-10A	Backing Ring	Backing Ring PP
14	4	K-35	Capscrew M8:30	Capscrew Headflange M8x30
15	1	K-15	Oil Seal Piston	Oil Seal 15307 for Piston
16	1	K-23	Main Flange	Main Flange Large
17	1	K-16	Cap Screw M5:16	Capscrew for Piston Flange m5x16
18	1	K-24	Spring	Steel Spring
19	1	K-25	Piston Shaft	Piston Shaft
20	1	MX-GB	MXD Gearbox	MXD Gearbox

14. WARRANTY

I-Feeder Technologies Warrants the product specified in this document for a period of 1 year from the purchase date. This warranty obligation is limited to the free replacement of the damaged parts due to any material or manufacture defect. This warranty does not include periodic maintenance and damage resulting from misuse.

The equipment must be sent to a I-Feeder Service Center with prepaid transport charges, and will be sent back with transport charges for customer's account.

The warranty document with sales date and shop stamp, or an invoice copy must be sent with the equipment.

I-Feeder Technologies can not be held liable for any loss of crop or product due to breakage.

MODEL

Sales date and shop stamp

SERIAL #



I-Feeder Technologies (UK) Ltd

web: www.ifdrtech.com email: johan@ifdrtech.com

